

# VITHAR L80N

## RS

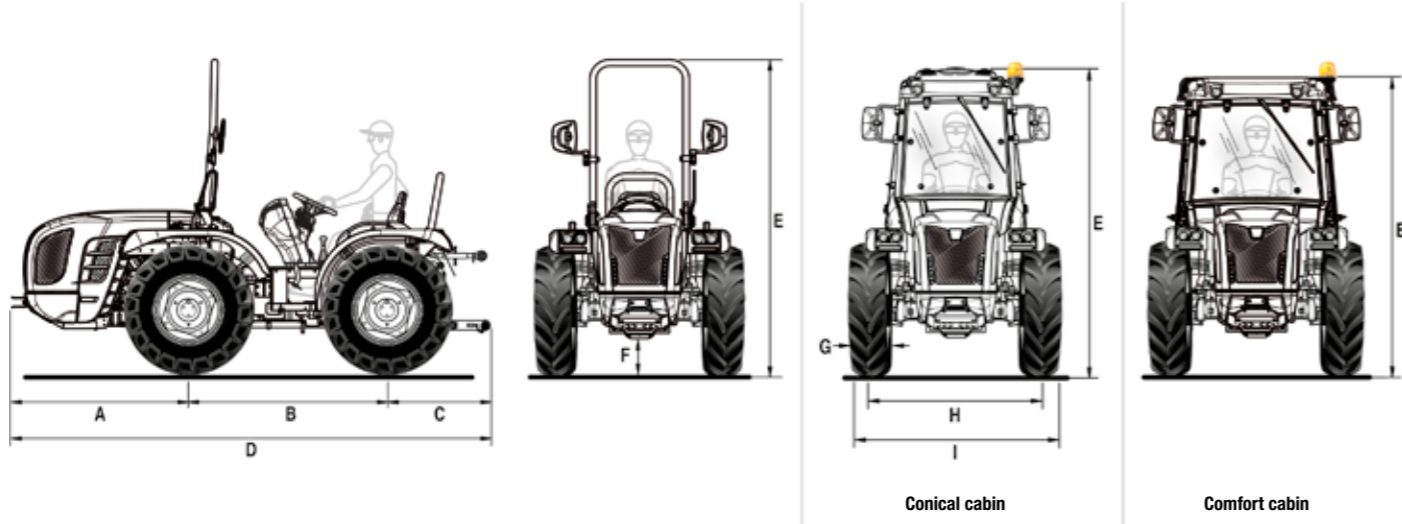

A	B	C	D	E min / max (with roll-bar)	E min / max (with Conical cabin)	E min / max (with Comfort cabin)	F min / max
1334	1495	932	3761	2269 / 2364	2122 / 2217	2069 / 2164	184 / 294



G Tyre width (mm)											
	343	245	282	320	286	316	343	368	394	391	
H Wheel track min/max (mm)	Mono	1098 / 1538	1046 / 1588	1098 / 1538	1098 / 1538	1134 / 1618	1134 / 1618	1134 / 1618	1260 / 1374	1260 / 1374	1240 / 1400
	Rev	1098 / 1538	1046 / 1588	1098 / 1538	1098 / 1538	1134 / 1618	1134 / 1618	1134 / 1618	1260 / 1374	1260 / 1374	1240 / 1400
I Width min/max (mm)	Mono	1441 / 1881	1291 / 1833	1380 / 1820	1418 / 1858	1420 / 1904	1450 / 1934	1477 / 1961	1628 / 1742	1654 / 1768	1631 / 1791
	Rev	1441 / 1881	1291 / 1833	1380 / 1820	1418 / 1858	1420 / 1904	1450 / 1934	1477 / 1961	1628 / 1742	1654 / 1768	1631 / 1791

TECHNICAL FEATURES	VITHAR L80N RS (monodirectional)	VITHAR L80N RS (reversible)
<b>ENGINE</b>	Kohler KDI 2504 TCR	
Number of cylinders	4	
Displacement (cc)	2482	
Aspiration	Turbo / Intercooler	
Fuel system	Direct injection Common-rail	
Emission level	Stage 3B	
Balancing	With counter-balance shaft	
Power (kW/hp)	55.4 / 75.3	
Nominal speed (rpm)	2,300	
Maximum torque (Nm/rpm)	300 / 1,500	
Speed management	Electronically regulated with a console with functions: increase and decrease of engine speed, memorize and recall a particular speed or switch off the electronic throttle and go to the minimum idle speed	
Cooling	Water	
Tank capacity (lt)	54	
<b>CHASSIS</b>	Swinging integral chassis OS-Frame with steering wheels	
<b>DRIVE</b>	Four-wheel drive, permanent	
<b>TRANSMISSION</b>	Synchronized gearbox: 32 speeds (16 forward and 16 reverse) with synchronized reverser	
Main clutch	Multidisc in oil bath with electronic hydraulic control and Pro-Act System. Clutch reactivity adjustable on 4 levels	
<b>DIFFERENTIAL</b>	Front and rear. With simultaneous or rear only differential lock and electro-hydraulic control	
<b>AXLES</b>	Front and rear, with epicyclic reduction units	
<b>REAR POWER TAKE-OFF</b>	Independent from the gearbox, 540/540E rpm and synchronized with the gearbox. Engageable under load with brake in disengaged position	
PTO clutch	Multidisc, in oil bath and electro-hydraulic control	
<b>HYDRAULIC SYSTEM</b>	Double circuit with independent pumps and heat exchanger	
Flow rate to the hydroguide and the electro-hydraulic controls (lt/min)	13.5	
Flow rate to the lift and the control valves (lt/min)	29.5 (optional oversized pump with flow rate 51 lt/min)	
Max hydraulic pressure (bar)	180	
<b>CONTROL VALVES</b>	Mechanical control	
Rear (standard)	For lift by rams: 1 single acting and 2 double acting For lift with draft and position control: 2 double acting	For lift by rams or with draft and position control: 2 double acting
Rear (optional)	For lift by rams or with draft and position control (in addition to the standard ones): 1 single acting and 1 double acting with float or 1 double acting and 1 double acting with float	For lift by rams (replacing the standard ones): 1 single acting, 1 double acting and 1 double acting with float or 3 double acting For lift with draft and position control (replacing the standard ones): 1 single acting and 1 double acting or 1 double acting and 1 double acting with float
Joystick (as optional)	Not available	With electronic control, complete with 1 single acting control valve with adjustable flow and free return, 5 double acting control valves (replacing the standard ones) and oversized pump
<b>REAR LIFT</b>	Standard: by two external rams. Optional: draft and position control	
Three-point hitches	Standard: standard couplers cat. 1 and 2. Optional: quick couplings cat. 1 and 2, arms with adjustable length or quick couplings, L-shaped, cat. 1 and 2, arms with adjustable length and hooks with adjustable width	
Three-point tie bar	With manual adjustment. Optional: hydraulically controlled upper link and tie rod link arm	
Lifting capacity at the end of the arms (kg)	2,300	
<b>ELECTRIC SYSTEM</b>	Battery 100 Ah, Alternator 95 A	
<b>DRIVING UNIT</b>	Monodirectional with semi-platform and suspended brakes-clutch pedals	Reversible with rotating platform suspended on silent-block and suspended brakes-clutch pedals
Seat	Standard: comfortable sprung seat adjustable according to the driver's weight, safety belt and 'man on board sensor'. Optional: 'Kab Seating' seat	Standard: comfortable sprung seat adjustable according to the driver's weight, safety belt and 'man on board sensor'. With gas spring for easy tipping. Optional: 'Kab Seating' and 'Grammer' pneumatic seat
<b>SERVICE BRAKES</b>	Oil immersed multidisc, acting on the rear transmission, with hydrostatic control	
Parking brake	Acting on the rear transmission, with hand lever	
<b>STEERING</b>	With hydrostatic steering by two rams, acting on the front wheels	With hydrostatic steering by two rams, acting on the front wheels. Flow deviator for steering unit
<b>SAFETY</b>	Standard: front homologated roll-bar, with gas springs for an easy lowering and lifting	
<b>CABIN (as optional)</b>	Not available	
<b>CONSOLE</b>	With TFT colour display to check: working time, engine speed, forwarding speed, PTO speed, instantaneous fuel consumption and current time. Analogue indicators with engine speed, engine coolant temperature and fuel level. Warning lights and acoustic alarm	
<b>TYRES (standard)</b>	280/70-18	
Optional	9.50-20 * 320/65-18 * 340/65-18 * 300/70-20 * 320/70-20 * 340/65-20 * 31x15.50-15 XTC and STG * 13.6-16 Garden	
<b>TOW HOOKS (standard)</b>	Front and rear CUNA	
Optional	Rear rotating or rear adjustable in height (Slider type) tow hooks, both EC approved or CUNA rear adjustable in height (Slider type)	
<b>WEIGHT OPERATIONAL</b>		
With roll-bar (kg)	2,150	
With cabin (kg)	2,400	
<b>OPTIONAL</b>	LED lights, front bumper, beacon lamp, front weight kg 120 and weights for wheels kg 50 each	
	Hydraulic suspension HDR with accumulator, LED lights, front bumper, beacon lamp, front weight kg 120 and weights for wheels kg 50 each	